

GP2W3270YP0F

IrDA Compliant Transceiver Module
9.6 to 115.2 kb/s (SIR LP)
Low Profile
Low Consumption Current



■ Description

The **GP2W3270YP0F** is an infrared transceiver module for IrDA ver. 1.4 (SIR LP).

The transceiver consists of a pin-photo diode, infrared emitter and control IC in a single package.

This device is built in LED constant current circuit.

This device have remote control transmission function (built in drive circuit).

■ Features

1. Compliant with the IrDA 1.4 (SIR LP)
Transmission speed : 9.6 to 115.2 kb/s
Transmission distance : 20 cm
2. Small package
L 7.6 × W 2.4 × H 1.5 mm
3. Peak emission wavelength : 890 nm
(Built-in shared single LED for RC and IrDA)
4. Side view type
5. Soldering reflow type
6. Shield type
7. Low consumption current due to shutdown function
(Consumption current at shutdown mode : Max. 0.1 μ A)
8. Operates from 2.4 to 3.6 V
9. With built in LED constant circuit
10. With remote control function
(built in drive circuit)
11. With V_{IO} terminal

■ Agency approvals/Compliance

1. Compliant with IEC60825-1 class 1 eye safety standard
2. Compliant with RoHS directive (2002/95/EC)
3. **Content status of six substances specified in “ Management Methods for Control of Pollution Caused by Electronic Information Products Regulation ” (popular name : *China RoHS*) (Chinese : 电子信息产品污染控制管理办法) ; refer to page 13**
4. Lead (Pb) free device

■ Applications

1. Mobile equipment
(Cellular phone, Pager, Smart phone, PDAs, Portable printer, etc.)
2. Digital imaging equipment
(Digital camera, Photo imaging printer)
3. POS equipment

Notice The content of data sheet is subject to change without prior notice.

In the absence of confirmation by device specification sheets, SHARP takes no responsibility for any defects that may occur in equipment using any SHARP devices shown in catalogs, data books, etc. Contact SHARP in order to obtain the latest device specification sheets before using any SHARP device.

Sheet No.: E3-A01101EN

Date Mar.01.2007

©SHARP Corporation

Recommended Size of Solder Creamed Paste (Reference)

Dimensions are shown for reference.
Please open the solder mask as below
so that the size of solder creamed paste
for this device before reflow soldering
must be as large as one of the foot
pattern land indicated for reference.

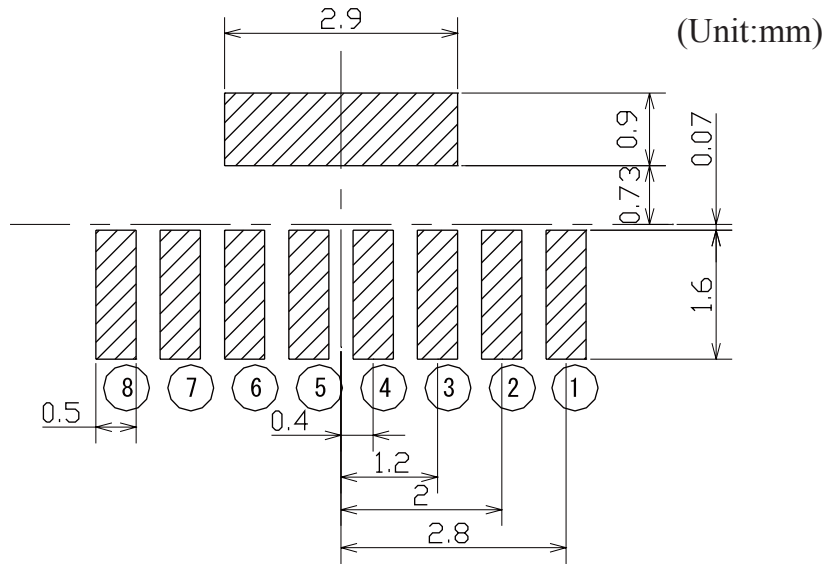

 : Solder paste area

■ Absolute Maximum Ratings (T_a=25°C)

Parameter	Symbol	Rating	Unit
Supply voltage	V _{CC}	0 to 6.0	V
VI/O Supply voltage	V _{IO}	0 to V _{CC}	V
LED Supply voltage	V _{LEDA}	0 to 7.0	V
SD, TXD Input voltage	V _{SD} , V _{TXD}	0 to V _{IO} +0.3	V
TXD-RC Input voltage	V _{TXDRC}	0 to V _{IO} +0.3	V
*1 Peak forward current 1	I _{FM1}	120	mA
*2 Peak forward current 2	I _{FM2}	300	mA
Operating temperature	T _{opr}	-40 to +85	°C
Storage temperature	T _{str}	-40 to +85	°C
*3 Soldering temperature	T _{sol}	260	°C

*1 Pulse width: 78.1μs, Duty ratio: 3/16

*2 Pulse width: 17.9μs, Duty ratio: 1/4

*3 Soldering reflow time: 10s

■ Electrical Characteristics (T_a=25°C, V_{CC}=3.3V)

Parameter	Symbol	Rating	MIN.	TYP.	MAX.	Unit
Current consumption at no input signal	I _{CC}	No input signal, output terminal open, V _{IHSD} =0V	—	70	100	μA
Current consumption at Shutdown mode	I _{CC-S}	No input signal, output terminal open, V _{IHSD} =V _{CC}	—	0.001	0.1	μA
High level output voltage	V _{OH}	V _{CC} =2.4 to 3.6V, I _{OH} =200μA ^{*4}	V _{IO} -0.4	—	—	V
Low level output voltage	V _{OL}	V _{CC} =2.4 to 3.6V, I _{OL} =200μA ^{*4}	—	—	0.4	V
Rise time	t _r	9.6kb/s ≤ BR ≤ 115.2kb/s, C _L =10pF, φ ≤ 15° ^{*4}	—	—	0.06	μs
Fall time	t _f		—	—	0.06	μs
Low level pulse width	t _w		1.35	2.25	3.3	μs
Maximum reception distance	L	9.6kb/s ≤ BR ≤ 115.2kb/s, C _L =10pF, φ ≤ 15° ^{*4}	21	—	—	cm
Input irradiance	E _e	9.6kb/s ≤ BR ≤ 115.2kb/s, C _L =10pF, φ ≤ 15° ^{*4}	—	—	0.081	W/m ²
Receiver wakeup Latency	t _l		—	—	200	μs
Receiver wakeup time	t _{sdw}	No input signal	—	—	200	μs
IrDA	Radiant intensity	BR=115.2kb/s, φ ≤ 15°, V _{IHTXD} =2.8V ^{*5}	5.5	—	28	mW/sr
	LED peak current		43	60	80	mA
	Rise time		—	—	0.6	μs
	Fall time		—	—	0.6	μs
	Peak emission wavelength		λ _p	875	890	900
Maximum optical pulse width	T _{OPWM}	TXD pin stuck High	30	80	250	μs
RC	Transmit distance	f=40kHz, duty=25%, φ =0°, V _{IHTXD} =2.8V ^{*5}	4	—	—	m
	Radiant intensity		20	—	100	mW/sr
	LED peak current		160	200	260	mA
	Peak emission wavelength		—	890	—	nm
	Maximum optical pulse width		T _{OPWM}	TXD pin stuck High	30	80

*4 Refer to Fig.2, 3, 4

*5 Refer to Fig.5, 6, 7

■ Recommended Operating Conditions

Parameter	Symbol	Conditions	Rating	Unit
Supply voltage	V_{CC}		2.4 to 3.6	V
V_{IO} voltage	V_{IO}		1.5 to V_{CC}	V
LED Supply voltage	V_{LEDA}		$V_{CC}-0.5$ to 6.5	V
Operating temperature	T_{opr}		-25 to +85	°C
Data rate	BR		9.6 to 115.2	kb/s
SD terminal input voltage Logic High	V_{IHSD}	Shutdown mode, $2.4V \leq V_{IO}$	$V_{CC} \times 0.67$ to V_{CC}	V
SD terminal input voltage Logic Low	V_{ILSD}	Normal mode, $2.4V \leq V_{IO}$	0.0 to $V_{CC} \times 0.33$	V
TDX high level input voltage	V_{IHTXD}	LED ON ^{*6}	$V_{IO} \times 0.67$ to V_{IO}	V
TDX low level input voltage	V_{ILXTD}	LED OFF ^{*6}	0.0 to $V_{IO} \times 0.33$	V
TDX-RC high level input voltage	$V_{IHTXDRC}$	LED ON ^{*6}	$V_{IO} \times 0.67$ to V_{IO}	V
TDX-RC low level input voltage	$V_{ILXTDRC}$	LED OFF ^{*6}	0.0 to $V_{IO} \times 0.33$	V

^{*6} Refer to Fig.7

■ Truth Table

Mode	SD	TXD	TXD-RC	Input signal	LED	RXD
Normal mode	0	0	0	No	Off	1
	0	0	0	IrDA	Off	0**
IrDA operation	0	0	1	*	On(60mA)	0
	0	1	0	*	On(60mA)	0
Remote control operation	1	0	1	*	On(200mA)	pull-up
Shutdown mode	1	0	0	*	Off	pull-up

* Don't care

** The pulse width is constant without depending on the transmission rate and the light intensity of input signal.

* RXD Equipment circuit

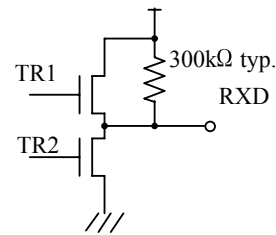
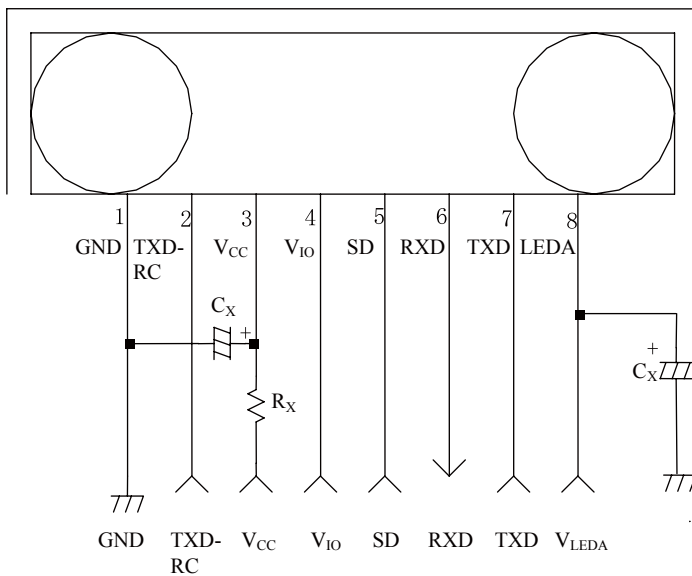

Fig.1 Recommended External Circuit



Components circuit	Recommended values
C_x	1 μ F/6.3V(Note)
R_x	1 to 15 Ω

(Note) Please choose the most suitable C_x according to the noise level and noise frequency of power supply.

Depending on noise level and noise frequency of power supply, C_x does not work well.

There are cases that some pulse noises from RXD other than signal will occur in certain communication area.

Please check by finish product that there are no problem at all communication area and data rate.

If there are any problem, please check by inserting R_x (1 to 15 Ω) in the circuit drawing.

Although there is no problem to distribute the voltage supply of V_{cc} , V_{IO} , and V_{LED} terminal, please apply the voltage to V_{cc} terminal first.

Fig.2 Input Signal Waveform(Receiver side)

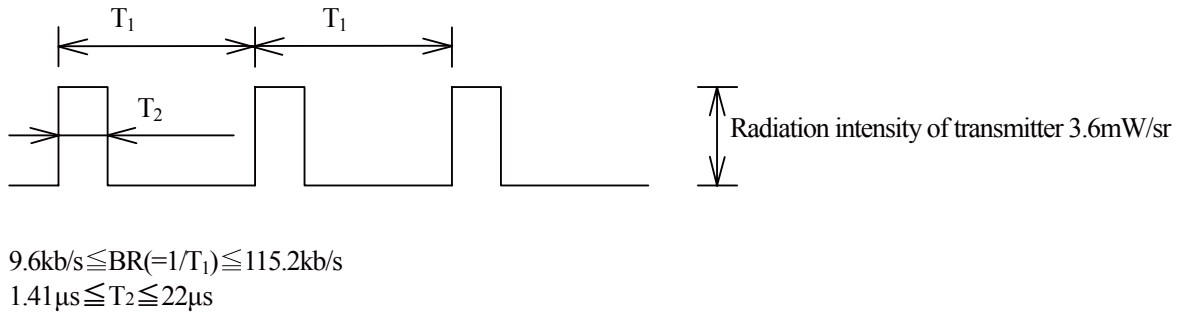

Fig.3 Output Waveform Specification(Receiver side)

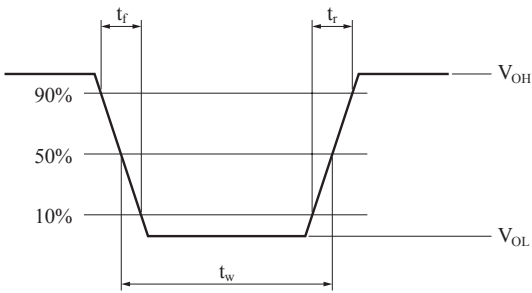
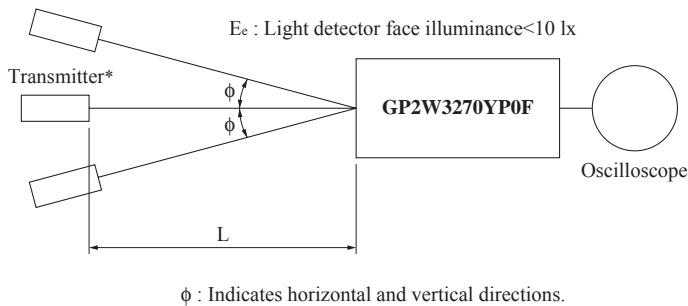

Fig.4 Standard Optical System(Receiver side)



*Transmitter shall use GP2W3270YP0F ($\lambda_p=890\text{nm TYP.}$) which is adjusted the radiation intensity at 3.6mW/sr .

Fig.5 Output Waveform Specification(Transmitter side)

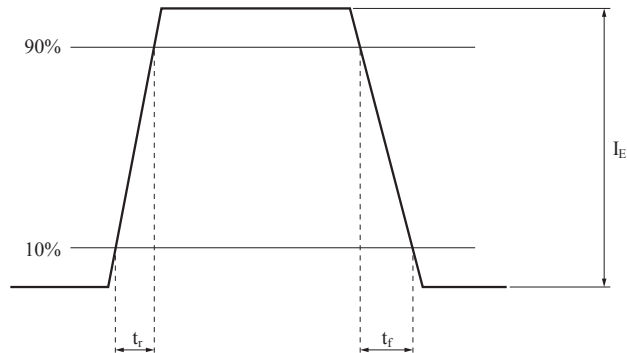

Fig.6 Standard Optical System(Transmitter side)

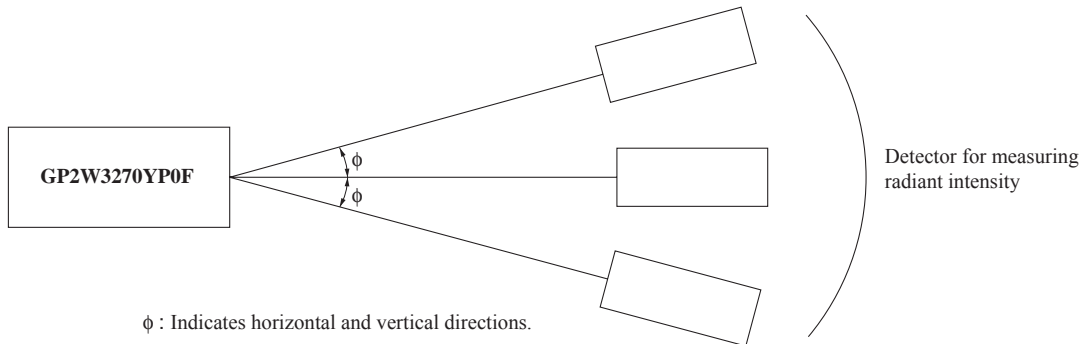
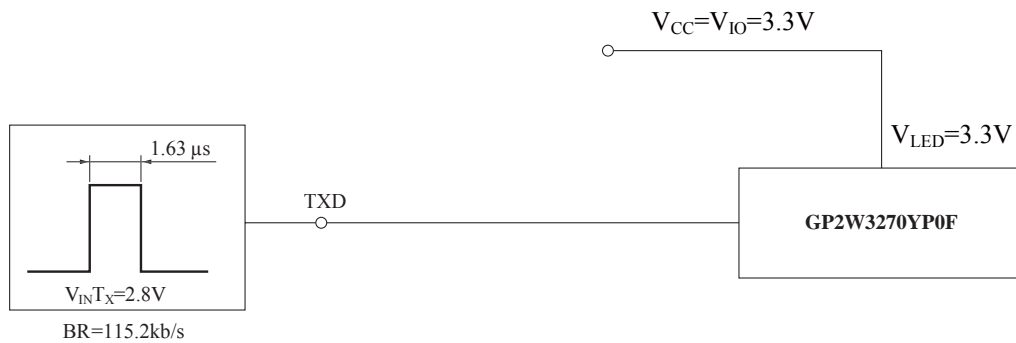

Fig.7 Recommended Circuit of Transmitter side



■Notes

- (1) When the system (program) is designed, the Turn Around Time shall be secured by considering 500 μ s or more that is specified to IrDA.
Then, this Turn Around Time means the time when this device does not temporarily detect the signal light, since the transmitted light from the transceiver reaches the detector side of the transceiver.
- (2) As it is necessary 200 μ s or more (at $T_a = 25^\circ\text{C}$, no input signal) to return from shut-down mode to ready-operation mode, please consider this point at the system (program) designing.
Also, please confirm thoroughly the operation in actual application.
- (3) When there is much external disturbing light source is located near this transceiver and the detector face receiver much external disturbing light, there is case that the pulse other than signal output is generated as noise on output terminal of this transceiver. Please consider the lay-out and structure to reduce disturbing light on the detector face.
- (4) In case that this sensor is adopted in IR communication system, please use it according to the signal method which is specified by [Serial Infrared Physical Layer Link Specification Version 1.4] published by Infrared Data Association. False operation may happen if the different signal method is used.
- (5) In circuit designing, make allowance for the degradation of light emitting diode output that results from long continuous operation. (50 % degradation/5 years)

■ Soldering Method

1. In case of solder reflow

Please carry out only two times soldering at the temperature and the time within the temperature profile as shown in the figure below. Reflow interval shall be within 3 days under conditions, 10 to 30°C, 70%RH or less.

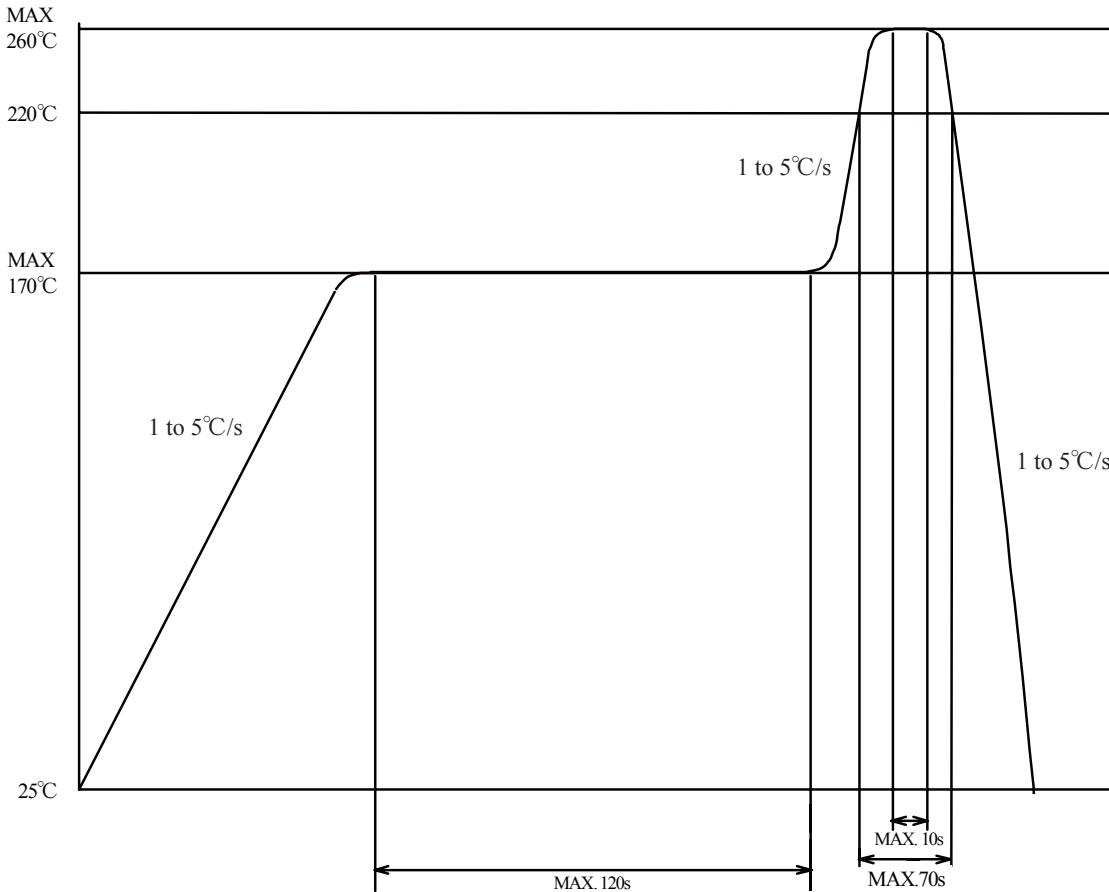

2. Other precautions

An infrared lamp used to heat up for soldering may cause a localized temperature rise in the resin. So keep the package temperature within that specified in Item 1. Also avoid immersing the resin part in the solder. Even if within the temperature profile above, there is the possibility that the gold wire in package is broken in case that the deformation of PCB gives the affection to lead pins. Please use after confirming the conditions fully by actual solder reflow machine.

3. Soldering

- Soldering iron shall be less than 25W, and temperature of point of soldering iron shall use at 350°C or less.
- Soldering time shall be within 5s.
- Soldered product shall treat at normal temperature.

■ Package specification

● Tape and Reel package
2000 pcs/reel

Taping materials

Name	Material	Countermeasure for ESD
Reel	PPE	Coped(conductivity)
Carrier tape	PC	Coped(conductivity)
Cover tape	PET	Coped(conductivity)

Carrier tape structure and Dimensions

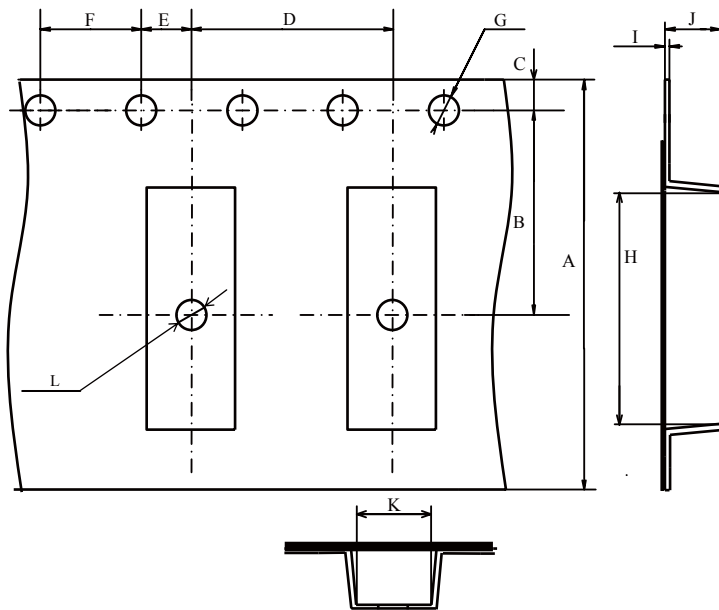

Dimension List

(Unit : mm)

A	B	C	D	E	F
16.0±0.3	7.5±0.1	1.75±0.10	8.0±0.1	2.0±0.1	4.0±0.1
G	H	I	J	K	L
$\phi 1.5^{+0.1}_{-0.0}$	7.85±0.10	0.32±0.05	1.8±0.1	2.7±0.1	$\phi 1.50^{+0.25}_{-0.00}$

Reel structure and Dimensions

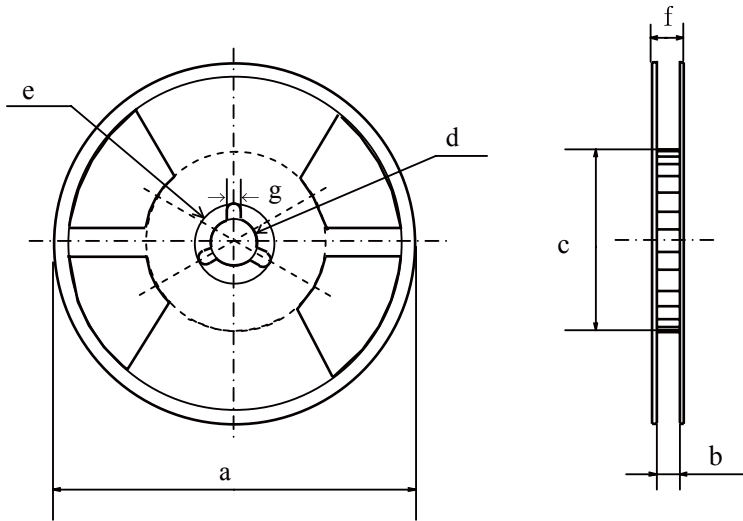

Dimension List			(Unit : mm)
a	b	c	d
330±2	17.5±1.0	100±1	13.0±0.2
e	f	g	
21.0±0.8	22.4±1.0	2.0±0.5	

Direction of product insertion

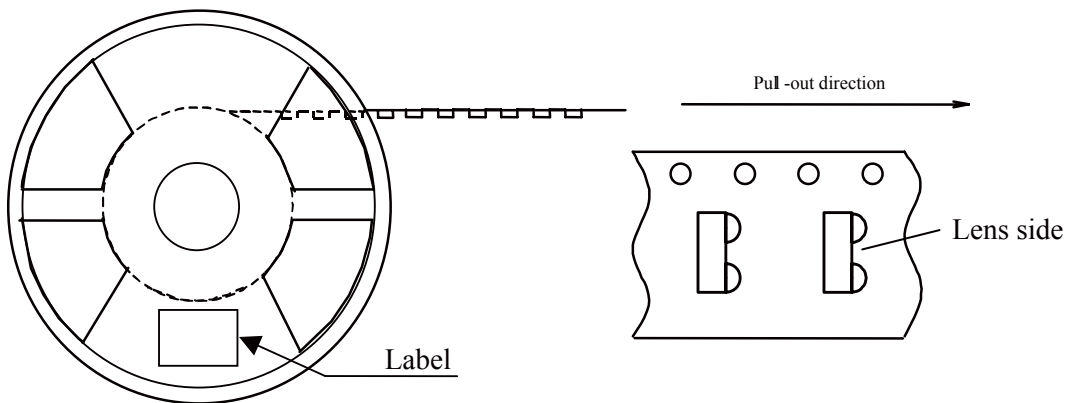

● **Cleaning Instructions**

Solvent cleaning :

Solvent temperature 45°C or less, Immersion for 3 min or less

Ultrasonic cleaning :

The effect to device by ultrasonic cleaning differs by cleaning bath size, ultrasonic power output, cleaning time, PCB size or device mounting condition etc.

Please test it in actual using condition and confirm that doesn't occur any defect before starting the ultrasonic cleaning. The cleaning shall be carried out with solvent below.

Recommended Solvent materials :

Ethyl alcohol, Methyl alcohol, Isopropyl alcohol

● **Presence of ODC etc.**

This product shall not contain the following materials.

And they are not used in the production process for this product.

Regulation substances : CFCs, Halon, Carbon tetrachloride, 1.1.1-Trichloroethane (Methylchloroform)

Specific brominated flame retardants such as the PBB and PBDE are not used in this product at all.

• **The RoHS directive (2002/95/EC)**

This product complies with the RoHS directive (2002/95/EC).

Object substances: lead, cadmium, hexavalent chromium, polybrominated biphenyls (PBB) and polybrominated diphenyl ethers (PBDE)

• **Content of six substances specified in “ Management Methods for Control of Pollution Caused by Electronic Information Products Regulation ” (Chinese : 电子信息产品污染控制管理办法)**

Category	Toxic and hazardous substances					
	Lead (Pb)	Mercury (Hg)	Cadmium (Cd)	Hexavalent chromium (Cr ⁶⁺)	Polybrominated biphenyls (PBB)	Polybrominated diphenyl ethers (PBDE)
Infrared data communication device	✓	✓	✓	✓	✓	✓

✓ : indicates that the content of the toxic and hazardous substance in all the homogeneous materials of the part is below the concentration limit requirement as described in SJ/T 11363-2006 standard.

■ Important Notices

- The circuit application examples in this publication are provided to explain representative applications of SHARP devices and are not intended to guarantee any circuit design or license any intellectual property rights. SHARP takes no responsibility for any problems related to any intellectual property right of a third party resulting from the use of SHARP's devices.
- Contact SHARP in order to obtain the latest device specification sheets before using any SHARP device. SHARP reserves the right to make changes in the specifications, characteristics, data, materials, structure, and other contents described herein at any time without notice in order to improve design or reliability. Manufacturing locations are also subject to change without notice.
- Observe the following points when using any devices in this publication. SHARP takes no responsibility for damage caused by improper use of the devices which does not meet the conditions and absolute maximum ratings to be used specified in the relevant specification sheet nor meet the following conditions:
 - (i) The devices in this publication are designed for use in general electronic equipment designs such as:
 - Personal computers
 - Office automation equipment
 - Telecommunication equipment [terminal]
 - Test and measurement equipment
 - Industrial control
 - Audio visual equipment
 - Consumer electronics
 - (ii) Measures such as fail-safe function and redundant design should be taken to ensure reliability and safety when SHARP devices are used for or in connection
 - with equipment that requires higher reliability such as:
 - Transportation control and safety equipment (i.e., aircraft, trains, automobiles, etc.)
 - Traffic signals
 - Gas leakage sensor breakers
 - Alarm equipment
 - Various safety devices, etc.
 - (iii) SHARP devices shall not be used for or in connection with equipment that requires an extremely high level of reliability and safety such as:
 - Space applications
 - Telecommunication equipment [trunk lines]
 - Nuclear power control equipment
 - Medical and other life support equipment (e.g., scuba).
- If the SHARP devices listed in this publication fall within the scope of strategic products described in the Foreign Exchange and Foreign Trade Law of Japan, it is necessary to obtain approval to export such SHARP devices.
- This publication is the proprietary product of SHARP and is copyrighted, with all rights reserved. Under the copyright laws, no part of this publication may be reproduced or transmitted in any form or by any means, electronic or mechanical, for any purpose, in whole or in part, without the express written permission of SHARP. Express written permission is also required before any use of this publication may be made by a third party.
- Contact and consult with a SHARP representative if there are any questions about the contents of this publication.